

# FL100-OF

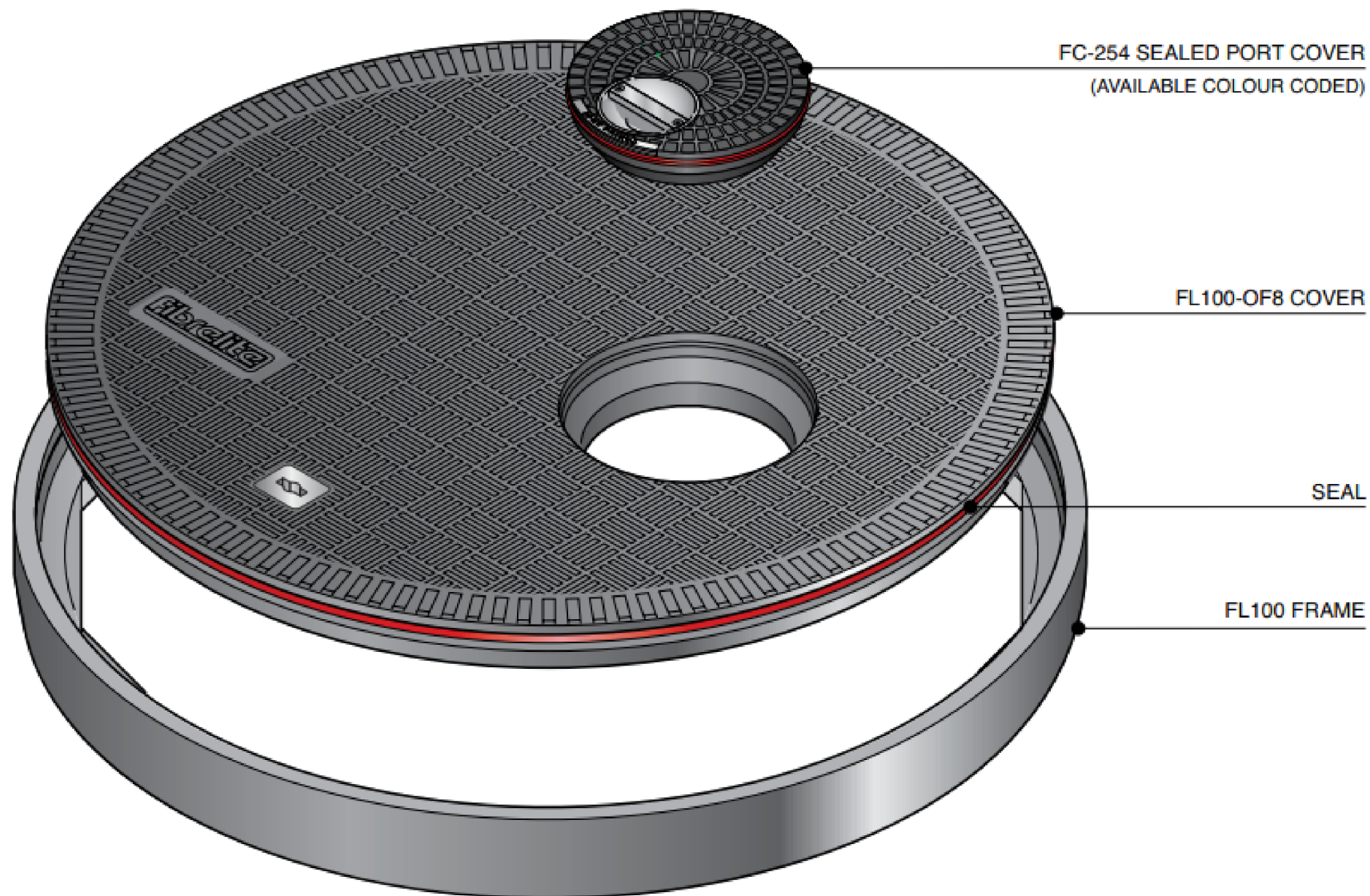

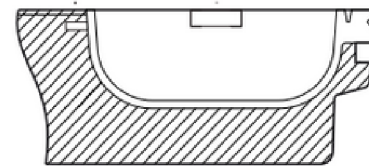
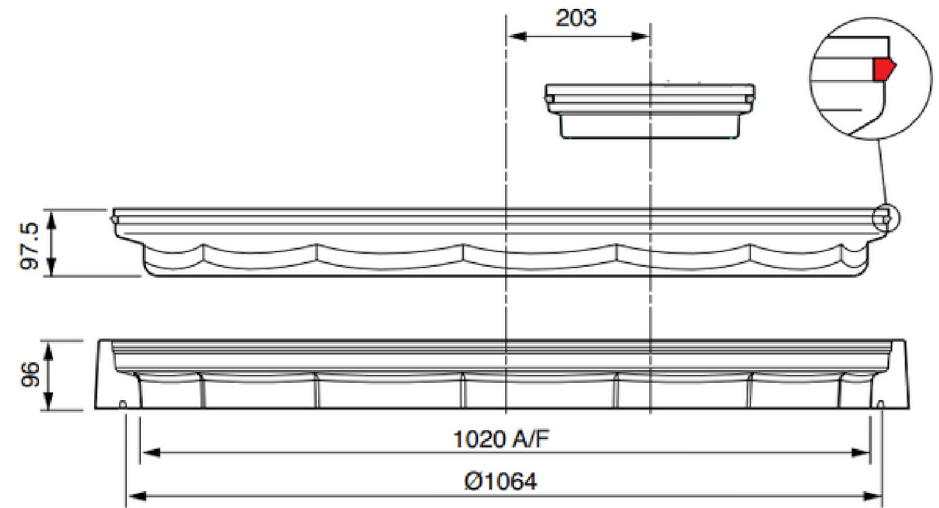
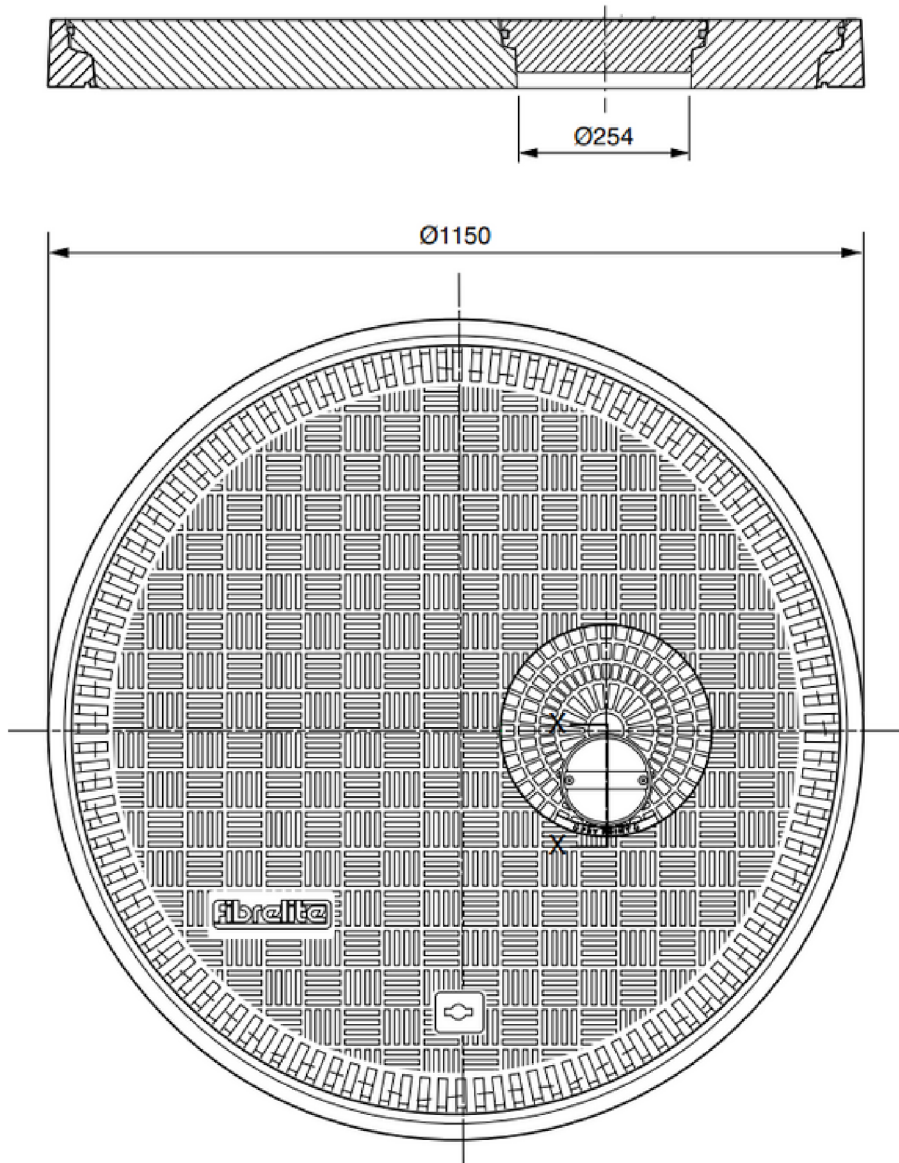

SECTION X - X  
HANDLE BOWL

Load Rating	Cover Weight	Frame Weight	Port Cover Weight
C250	48 kg	11 kg	3 kg

## CONCRETE

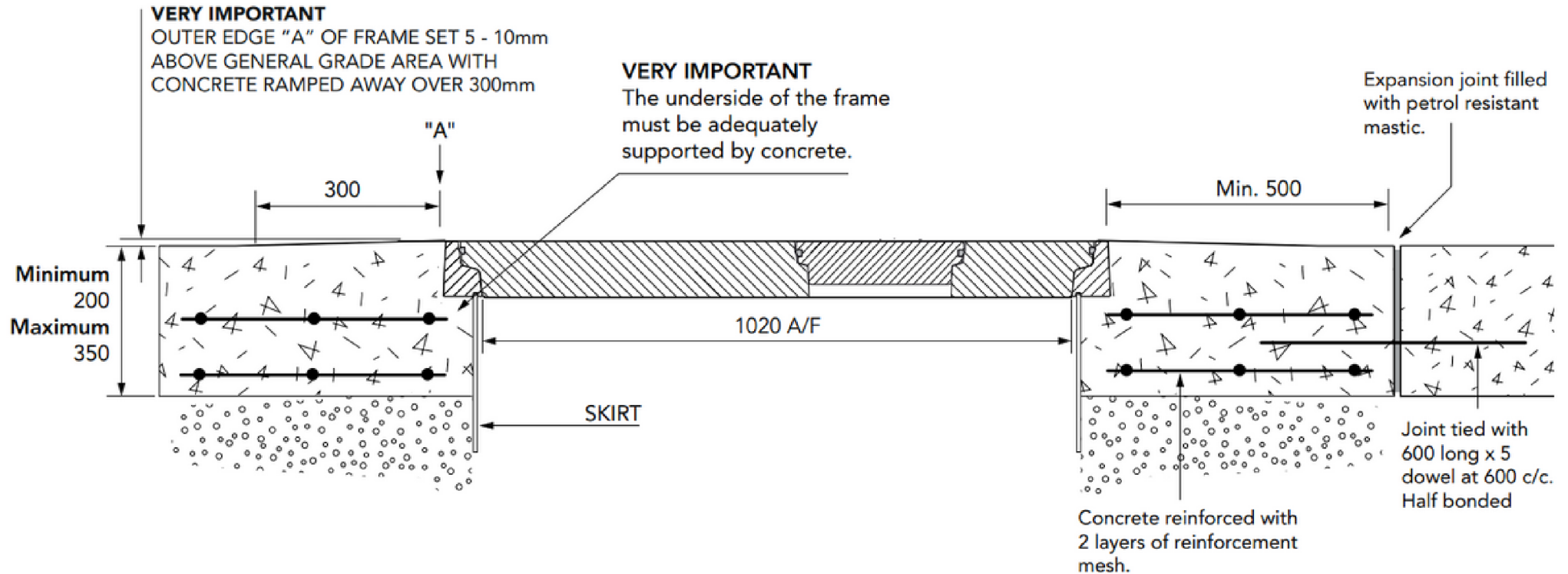

## TARMACADAM

