

FL600-CD

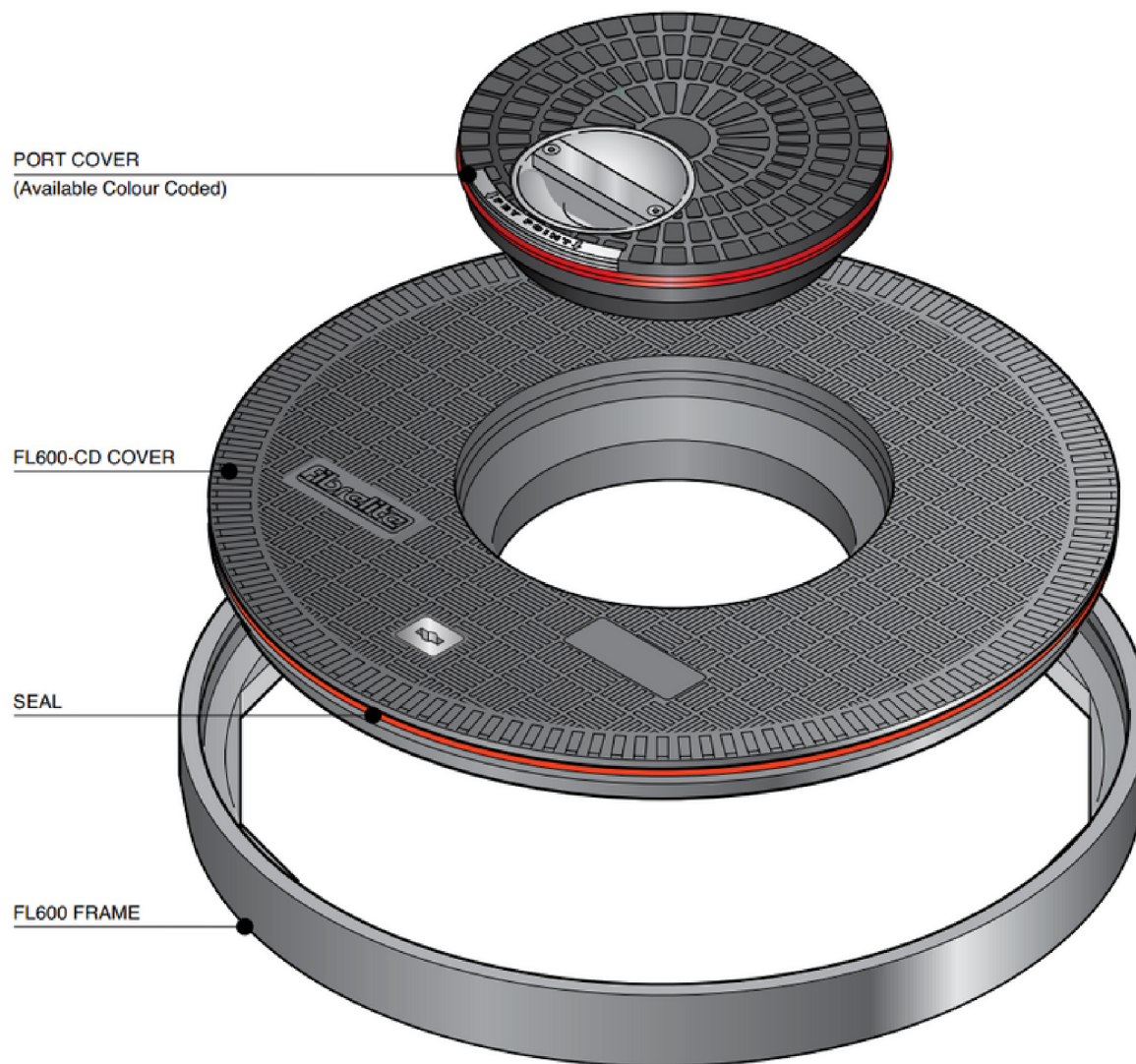

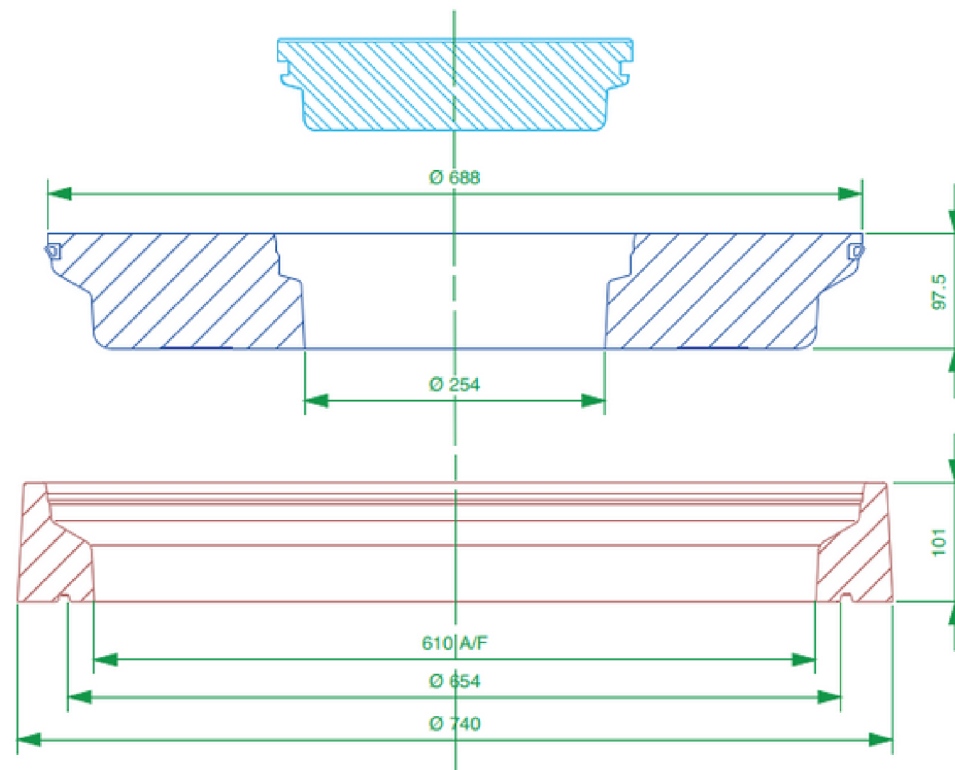
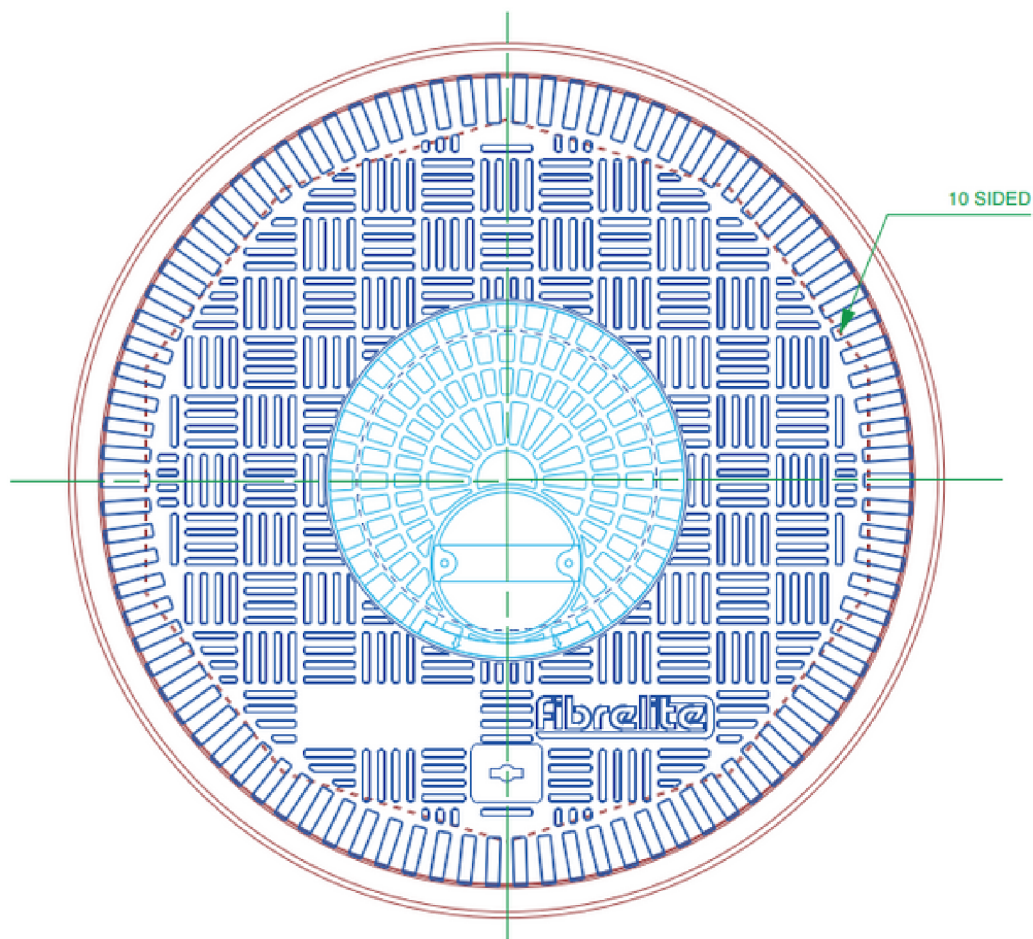

Load Rating	Cover Weight	Frame Weight
B125	7.5 kg	6.5 kg
C250	21 kg	6.5 kg
D400	26 kg	6.5 kg

CONCRETE

VERY IMPORTANT

OUTER EDGE "A" OF FRAME SET 5MM ABOVE GENERAL FORECOURT AREA WITH CONCRETE RAMPED AWAY OVER 300MM

VERY IMPORTANT

The underside of the frame must be adequately supported by concrete.

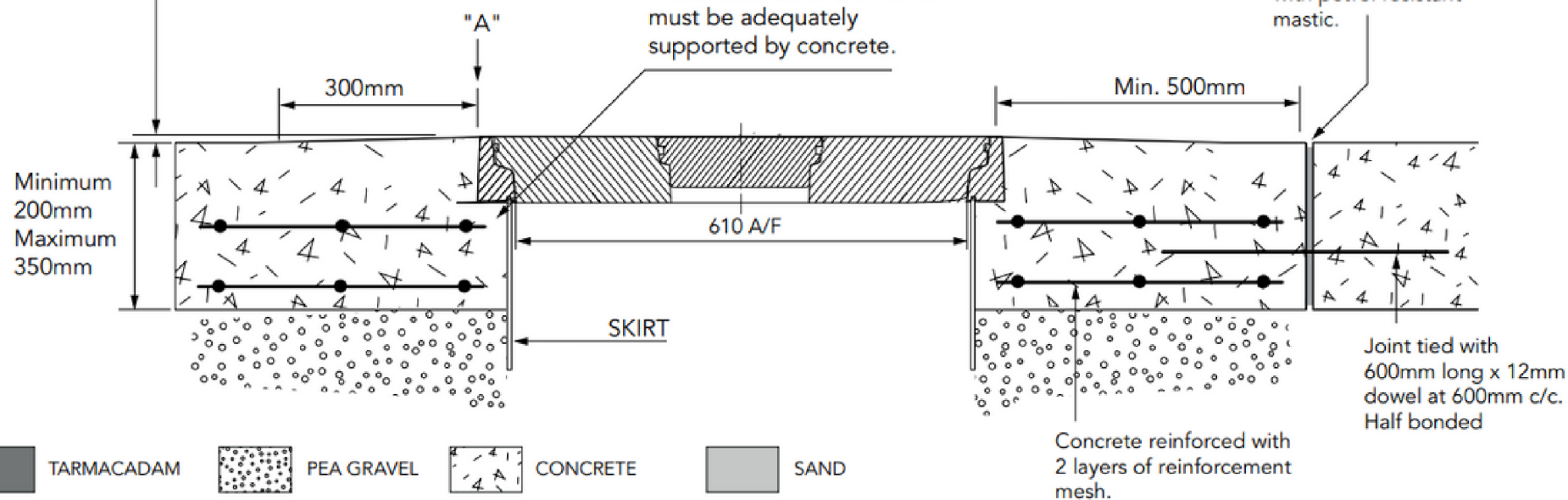

TARMACADAM

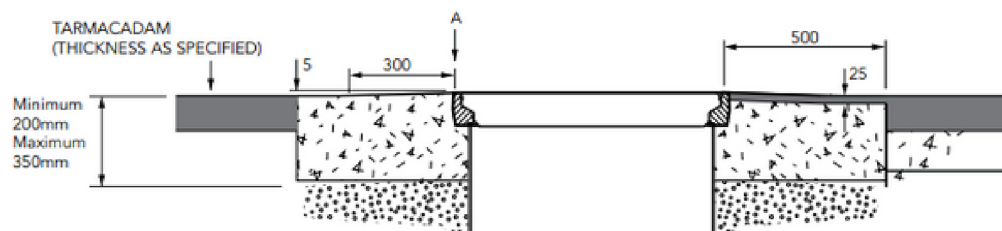

SETTS

