

FL600

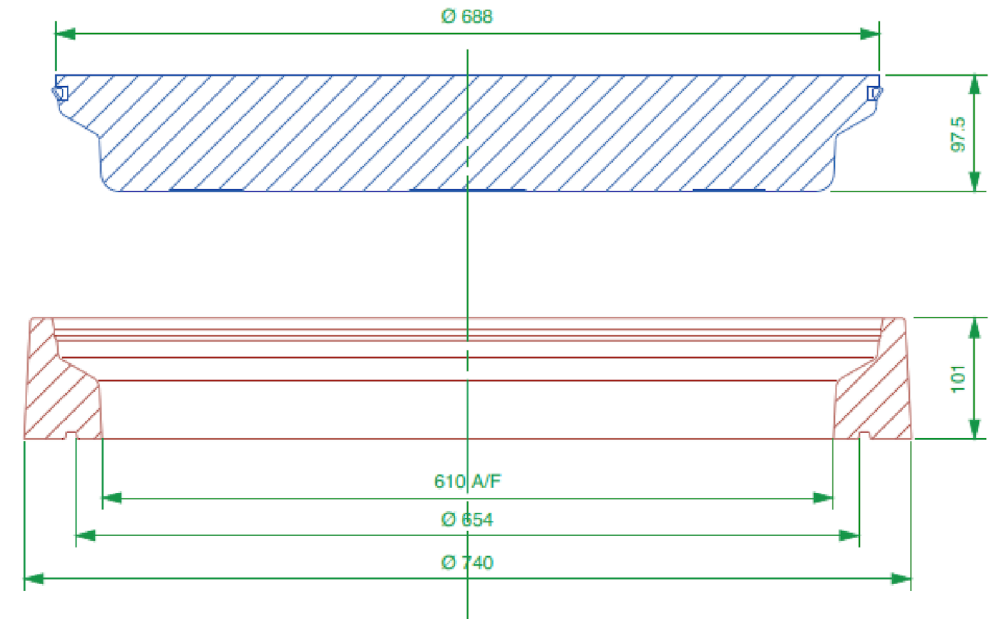

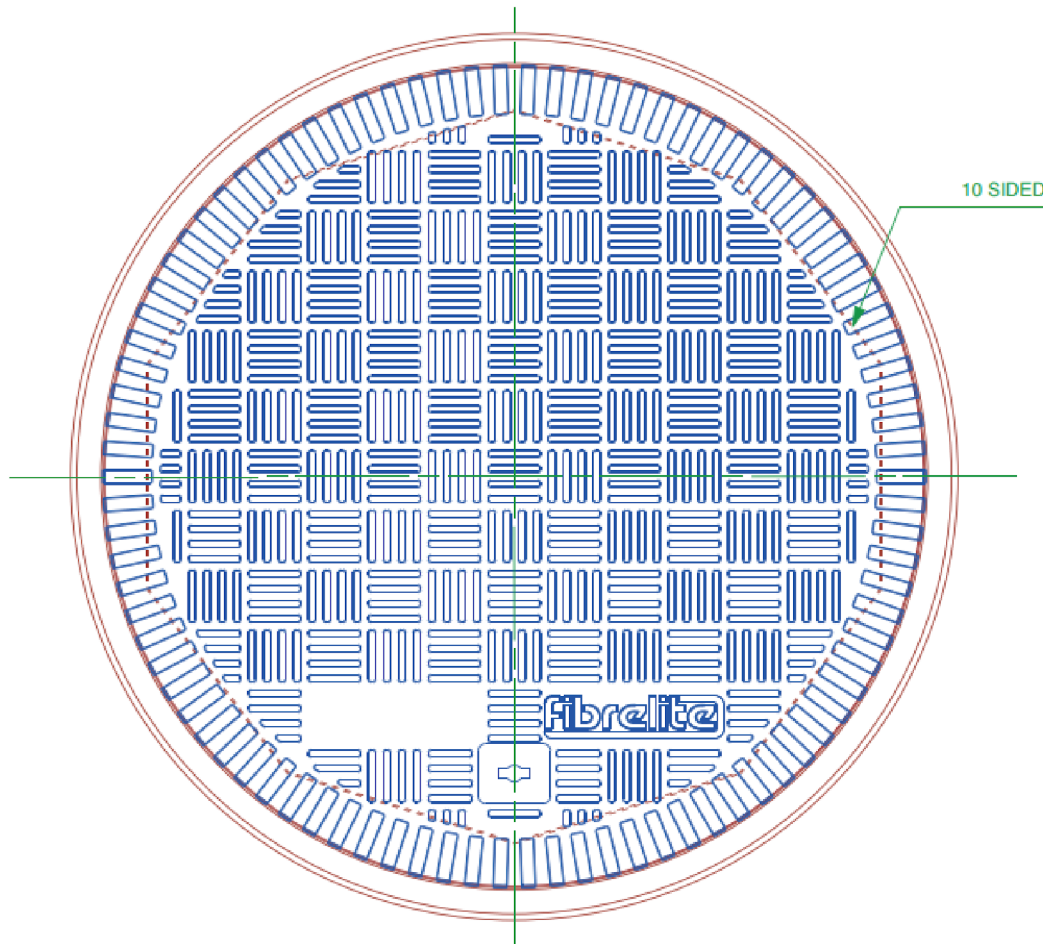

Load Rating	Cover Weight	Frame Weight
A15	13 kg	6.5 kg
B125	14 kg	6.5 kg
C250	18 kg	6.5 kg
D400	25 kg	6.5 kg

CONCRETE

VERY IMPORTANT

OUTER EDGE "A" OF FRAME SET 5MM ABOVE GENERAL FORECOURT AREA WITH CONCRETE RAMPED AWAY OVER 300MM

VERY IMPORTANT

The underside of the frame must be adequately supported by concrete.

Expansion joint filled with petrol resistant mastic.

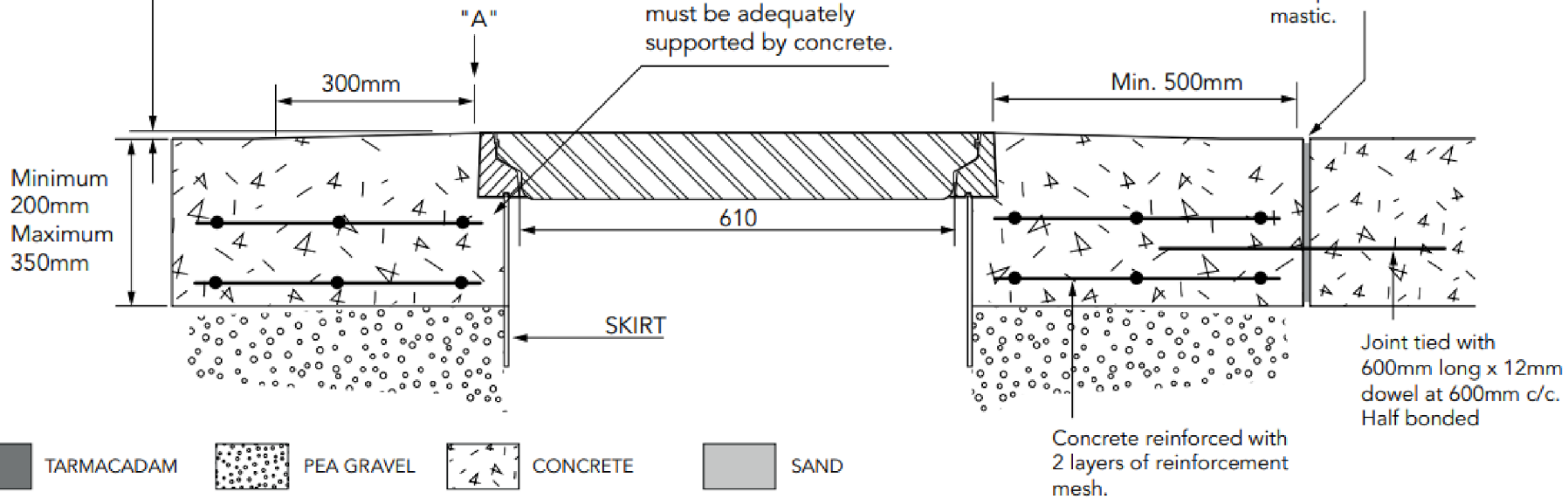

TARMACADAM

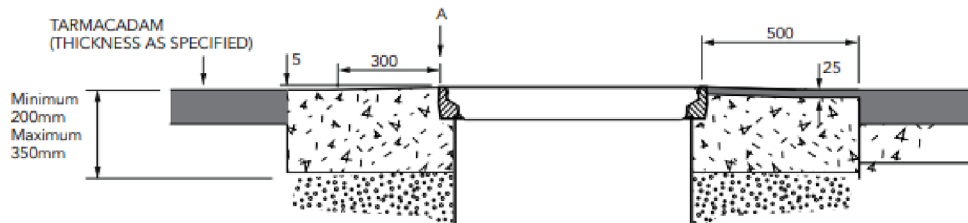

SETTS

