

## FL760

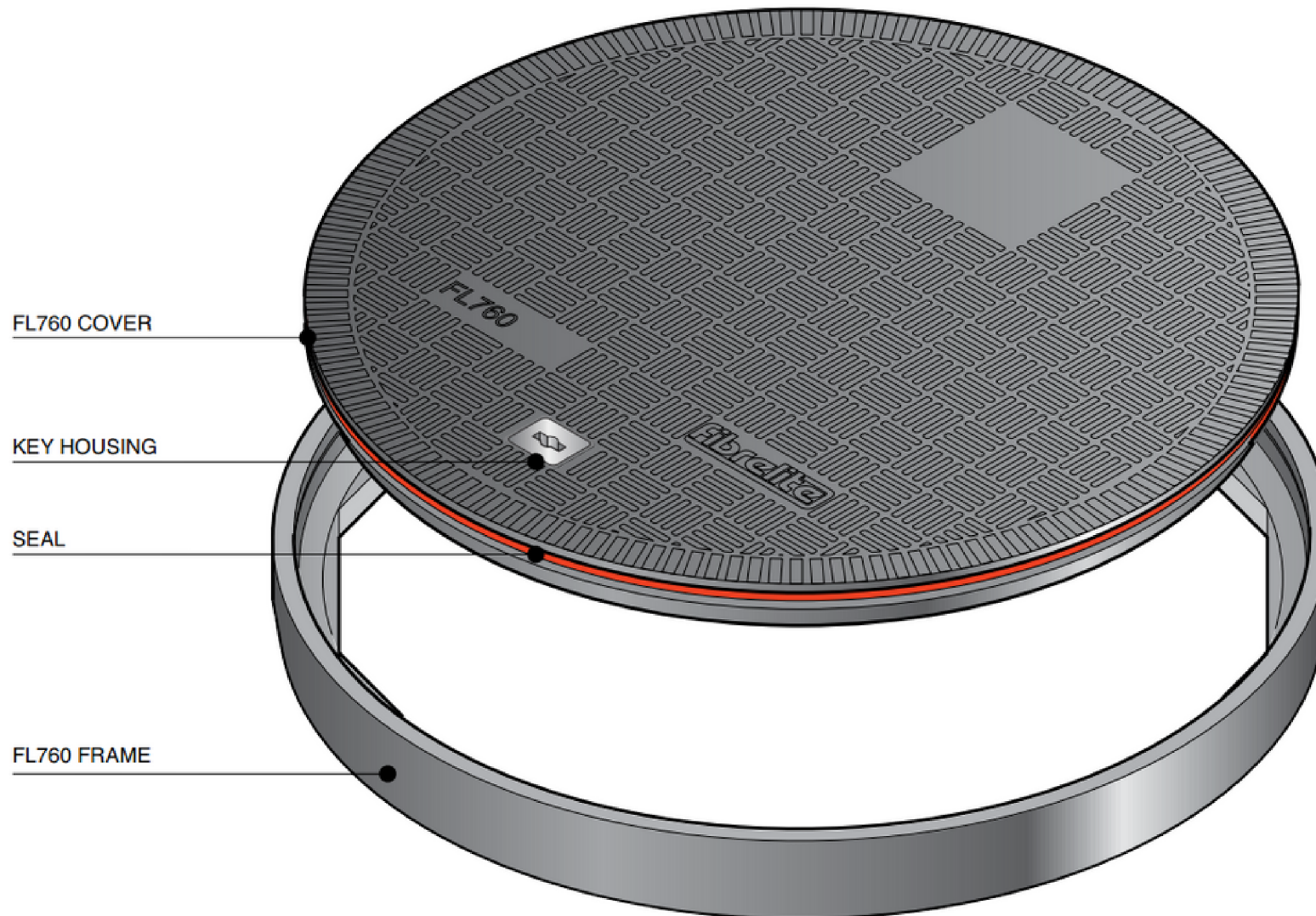

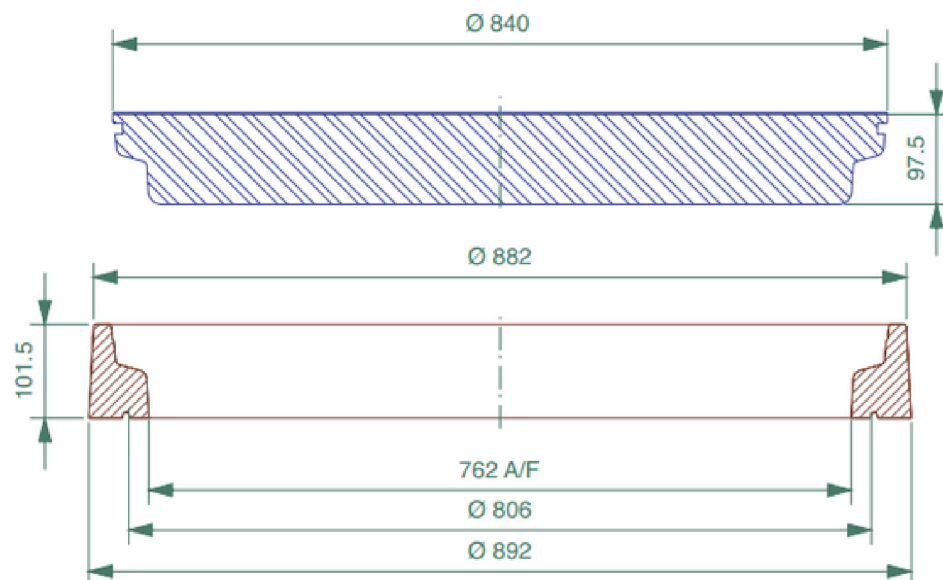
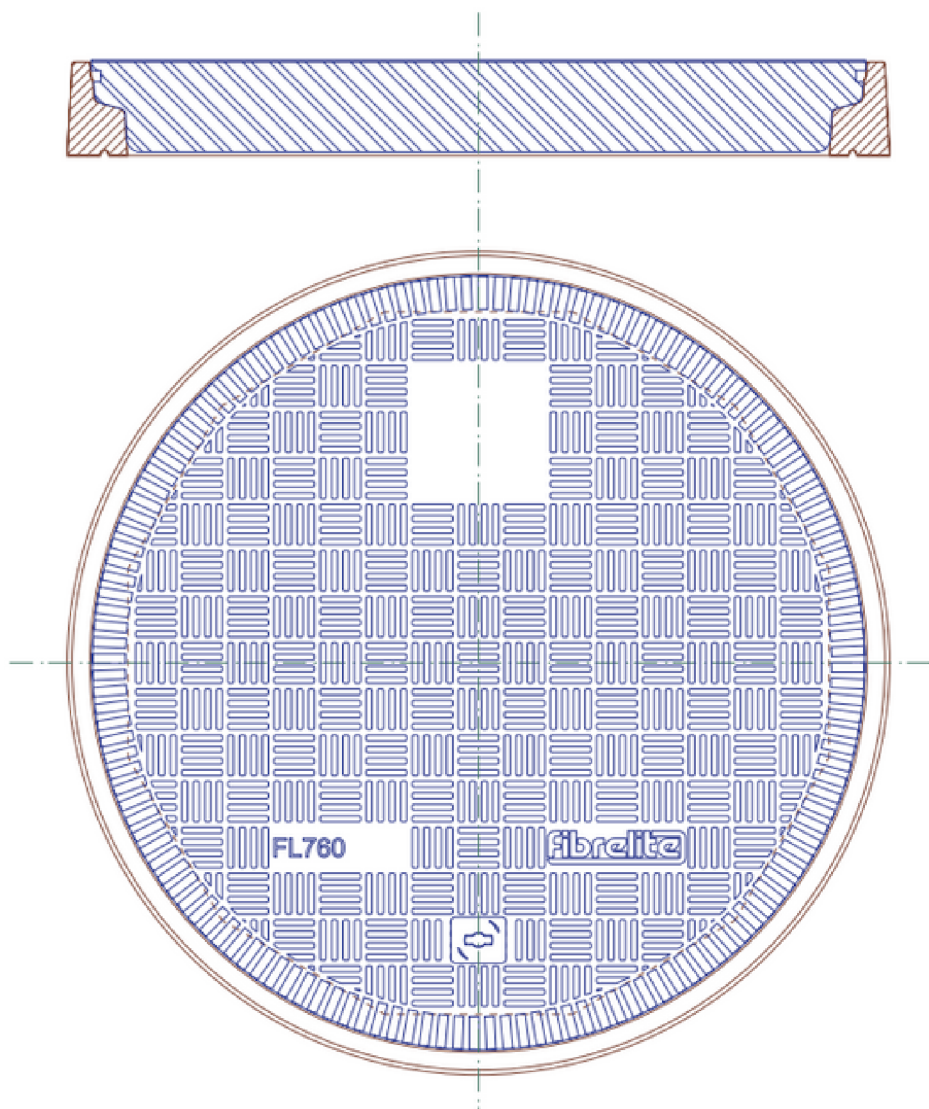

Load Rating	Cover Weight	Frame Weight
B125	--	8 kg
C250	28 kg	8 kg
D400	38 kg	8 kg

## CONCRETE

### VERY IMPORTANT

OUTER EDGE "A" OF FRAME SET 5MM ABOVE GENERAL FORECOURT AREA WITH CONCRETE RAMPED AWAY OVER 300MM

### VERY IMPORTANT

The underside of the frame must be adequately supported by concrete.

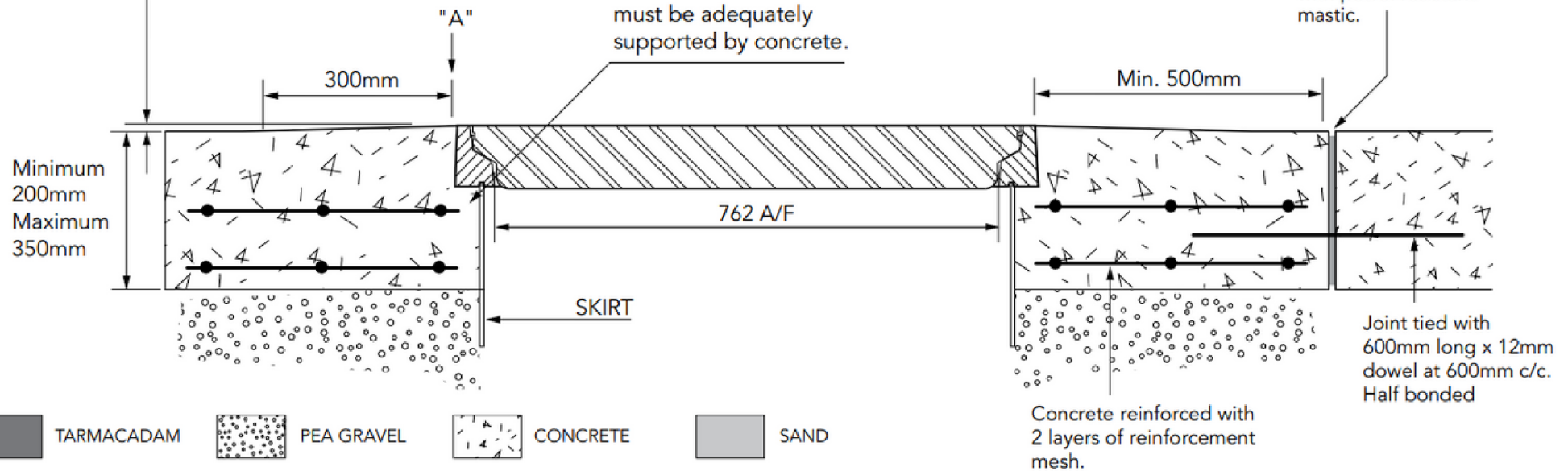

## TARMACADAM

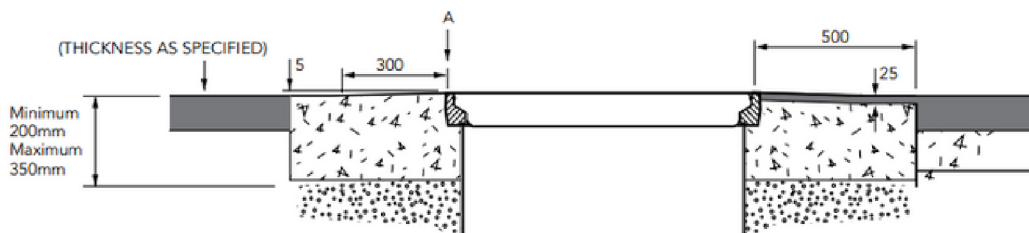

## SETTS

