

FL90-CF

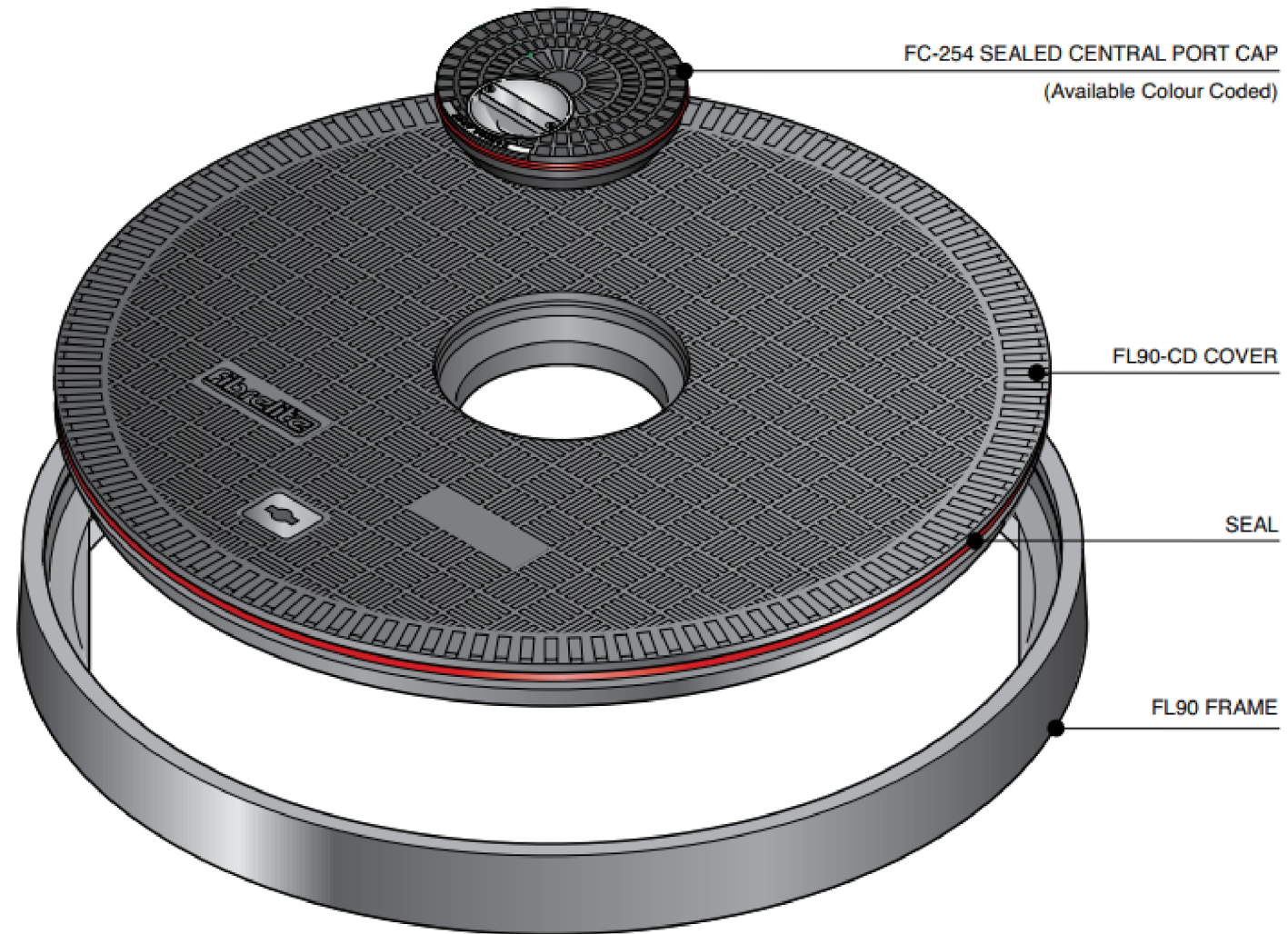

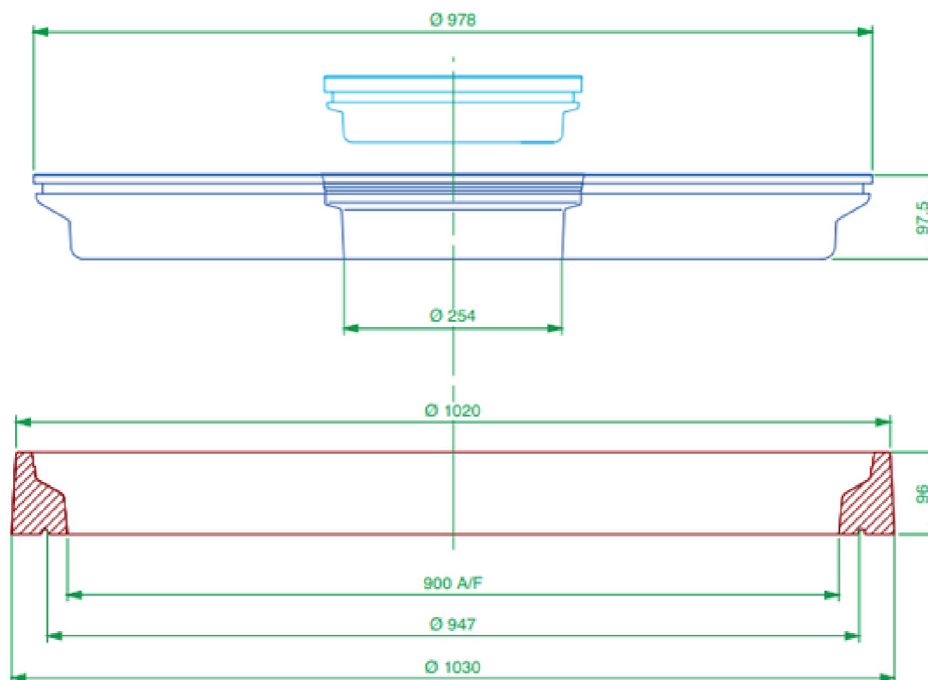
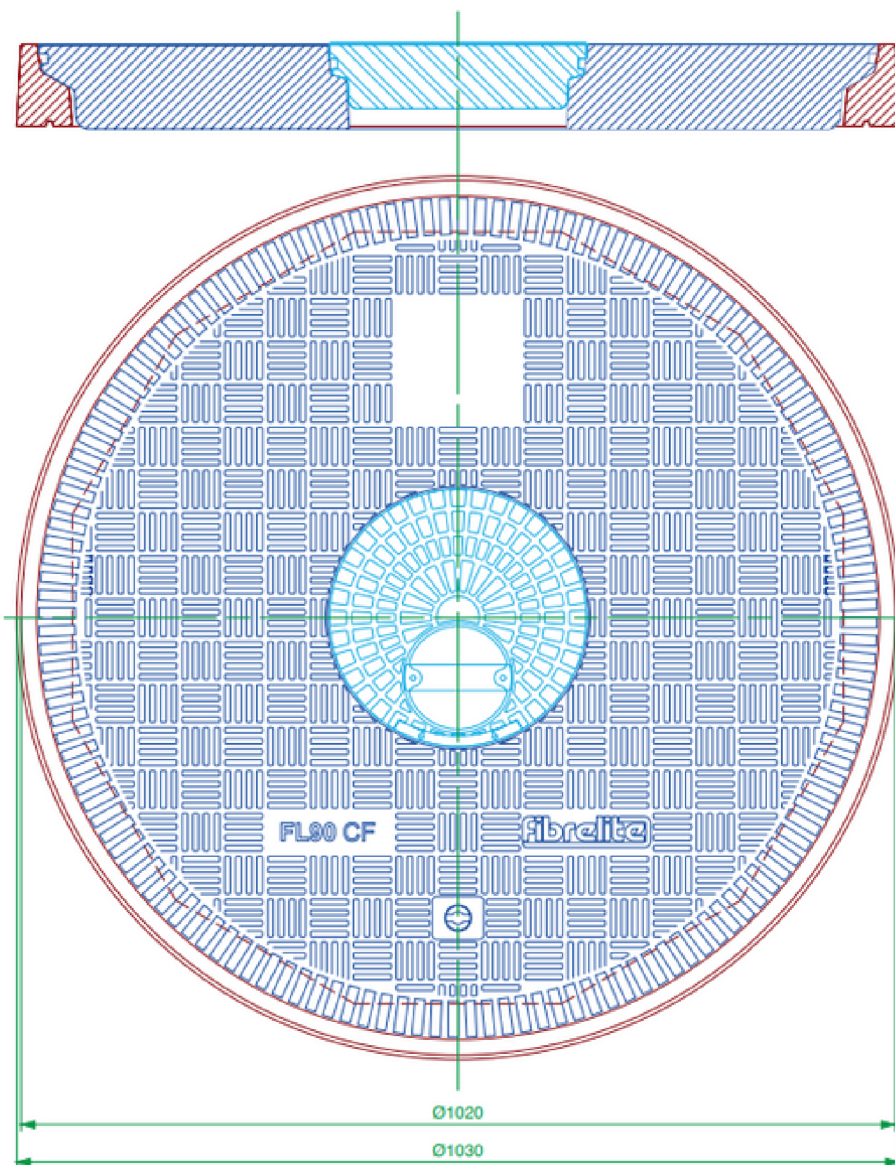

Load Rating	Cover Weight	Frame Weight
B125	25 kg	9.5 kg
C250	34 kg	9.5 kg
D400	47 kg	9.5 kg

CONCRETE

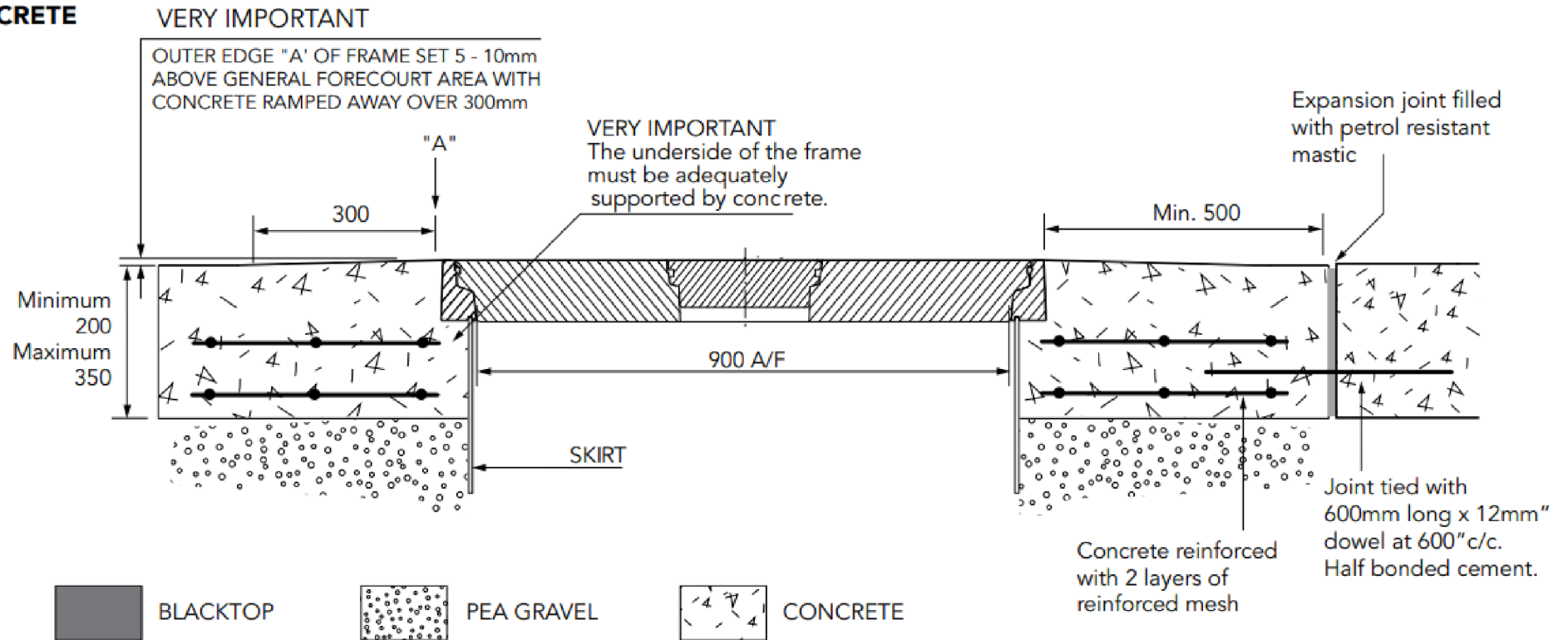

TARMACADAM

