

# FL90

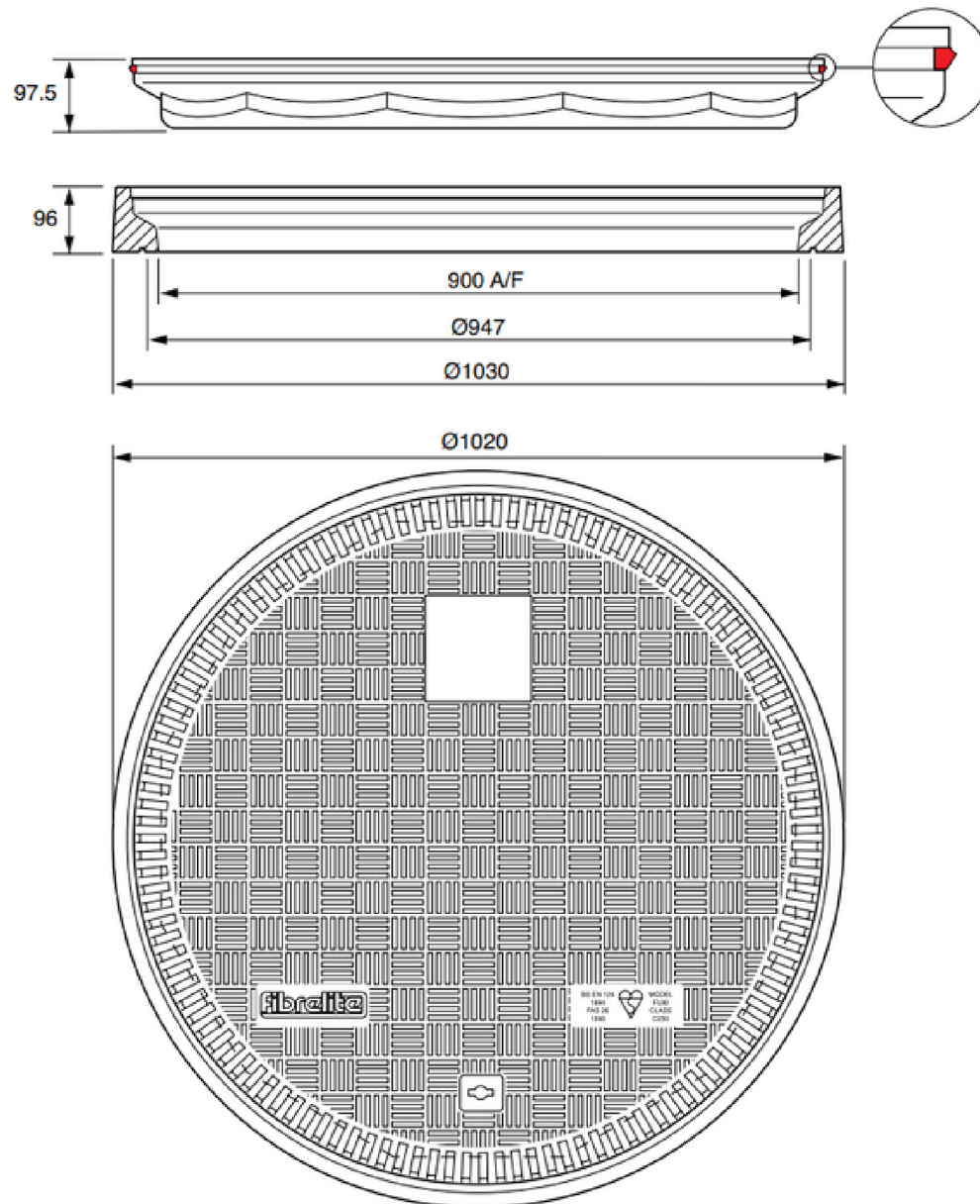



Load Rating	Cover Weight	Frame Weight
B125	21 kg	9.5 kg
TCR	31.5 kg	9.5 kg
C250*	31.5 kg	9.5 kg
D400	48 kg	9.5 kg
F900	88 kg	9.5 kg

\* Awarded British Standard Kite Mark

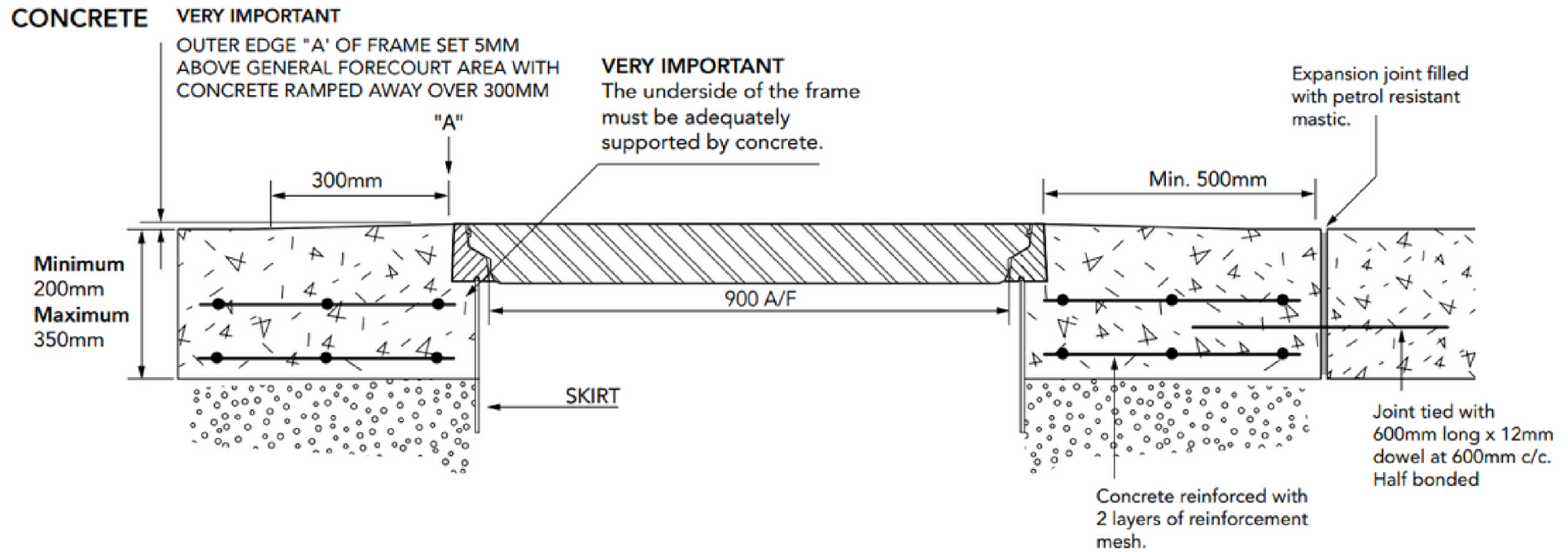

## TARMACADAM

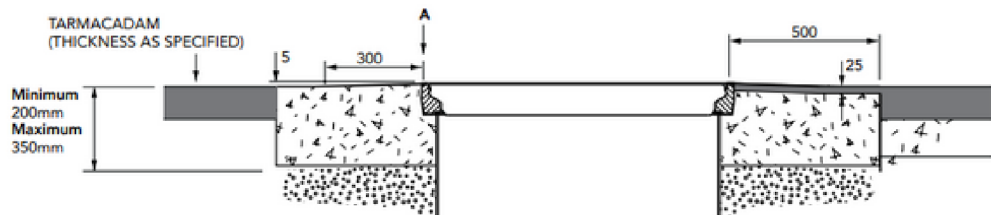

## SETTS

